

RoHS

本产品符合我司QA-3-04-005
环境管理物质标准规范

包装图

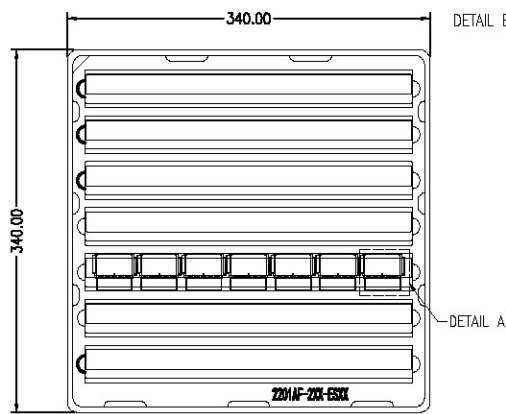

The upper and lower disks must be stacked in reverse order
上下两盘反向堆叠

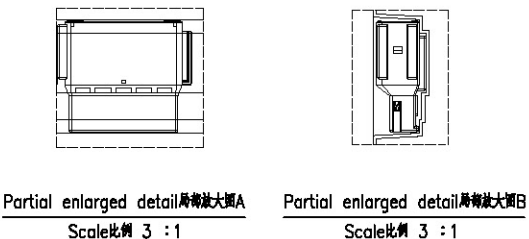

| | |
|----------------------------------|---------------------|
| Applicable Product No. 适用产品料号 | 2201AF-2*XXX-ESXX-X |
|----------------------------------|---------------------|

| Poles Pin位 | Pcs/Tray Pcs/盘 | Tray/Carton 盘/箱 | Pcs/Carton Pcs/箱 |
|---------------|-------------------|--------------------|---------------------|
| 2*06 | 84 | 11 | 924 |
| 2*08 | 70 | 11 | 770 |
| 2*10 | 63 | 11 | 693 |
| 2*12 | 56 | 11 | 616 |
| 2*14 | 42 | 11 | 462 |
| 2*16 | 42 | 11 | 462 |
| 2*18 | 42 | 11 | 462 |
| 2*20 | 35 | 11 | 385 |



Step步骤1:

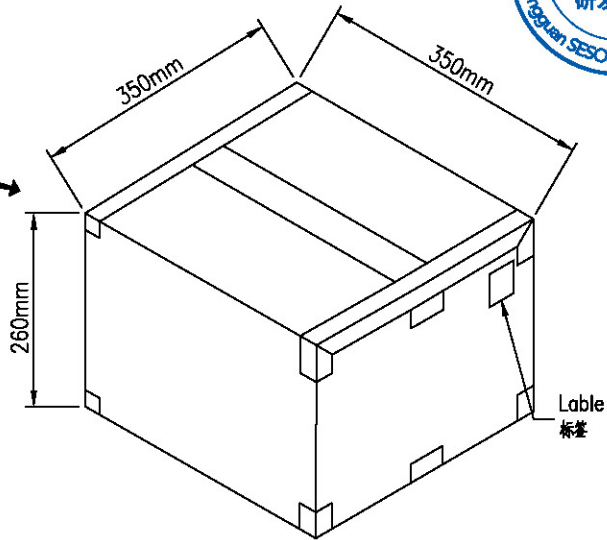
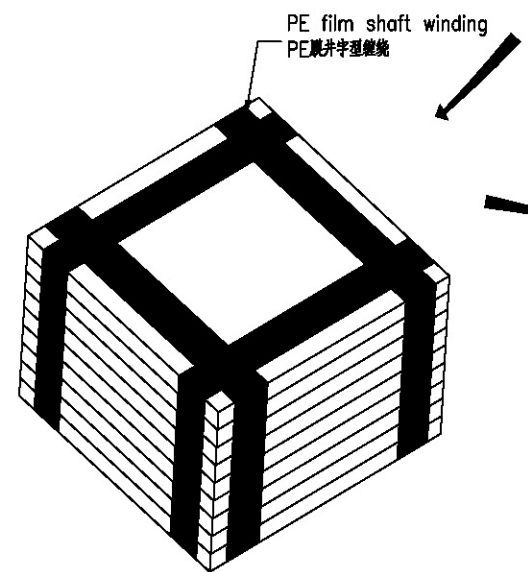

Step步骤2:

Step步骤3:

Packing step包装步骤:
 Step 1: Place the inspected product with TPA facing downwards, arrange neatly and in the same direction into the uptake plastic tray, the quantity cannot be reduced.
 步骤1: 将检验好的产品TPA朝下,整齐并方向一致地放入吸取盘,不可少数。
 Specification of the uptake plastic tray: 2201SP-3400*3400*215
 吸取盘规格: 2201SP-3400*3400*215
 Step 2: Overlap the uptake plastic tray, when it overlaps, adjacent upper and lower tray need to be rotated 180 degrees for stacking, one empty uptake plastic tray is stacked together in every 11 products, and put one on the top layer as well, fold them up into a bundle, then cross and parallel wrap with PE film.
 步骤2: 将吸取盘重叠,在重叠吸取盘时,相邻上下两盘需要旋转180度堆叠,每11盘产品加取顶层1PCS空吸取盘叠起来为1扎,然后用PE膜并字型缠绕。
 Step 3: One bundle per carton, put it flat into the carton, then seal the carton with transparent tape, attach outer carton label.
 步骤3: 每1扎为一捆,平整地放入外箱内,然后用透明胶带封箱,贴上外箱标签。
 Note: when the carton is not full, filling material is required, cannot shake too much.
 注: 不满箱时,需使用填充物,不可晃动太大。
 Carton size: CB-350*350*260KK
 纸箱规格: CB-350*350*260KK
 Carton material: K=K; Carton thickness: 6~7mm
 纸箱材质: K=K; 纸箱厚度: 6~7mm

| 日期 | 版次 | 变更编号 | 变更内容说明 | 变更人 | 核准 |
|----------|----|------|-------------------------|----------------|------------------|
| 20240116 | A1 | / | Update Drawing 更新图面 | Tim Teng 滕敏 | Larry Yang 杨秉 |
| 20230617 | A0 | / | Initial release 首次发行 | / | Larry Yang 杨秉 |

一般公差
.X ±0.35
.XX ±0.25
.XXX ±0.15
X: ±2

SMS 东莞市思索技术股份有限公司
Dongguan SESO Technology Co., Ltd.

核准 审查 制作 日期
杨秉 刘中华 滕敏 2023/06/17

料号: PK-2201AF-2*XXX-ESXX-X
名称: 2.20mm Housing Packing

| 单位 | 比例 | 页次 | 版本 | 编号 |
|----|-----|-----|----|-------|
| mm | 1:1 | 1/1 | A1 | A-000 |

RoHS

本产品符合我司QA-3-04-005
环境管理物质标准规范

包装图

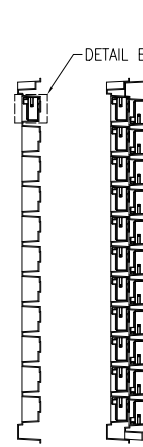
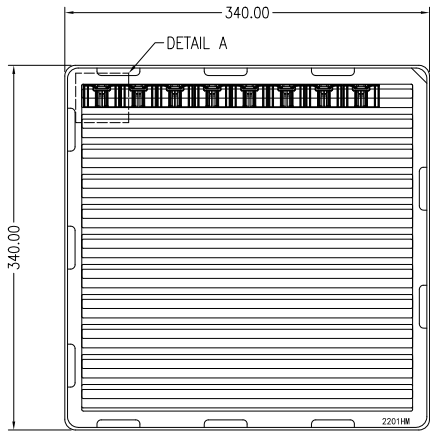

The upper and lower disks must be stacked in reverse order
上下两盘需反向堆叠

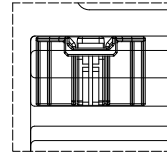

Partial enlarged detail局部放大图A
Scale比例 3 : 1

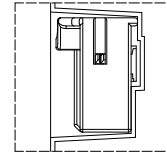

Partial enlarged detail局部放大图B
Scale比例 5 : 1

Step步骤1:

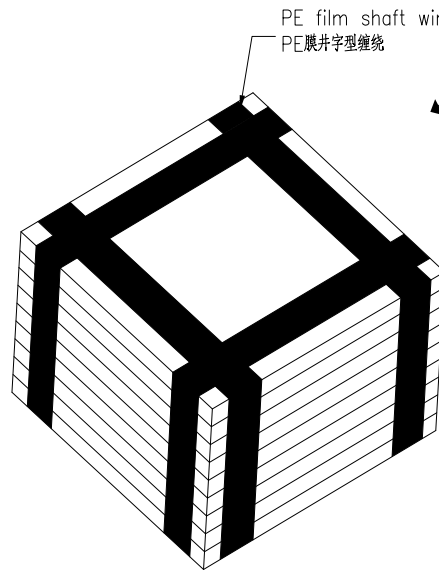

Step步骤2:

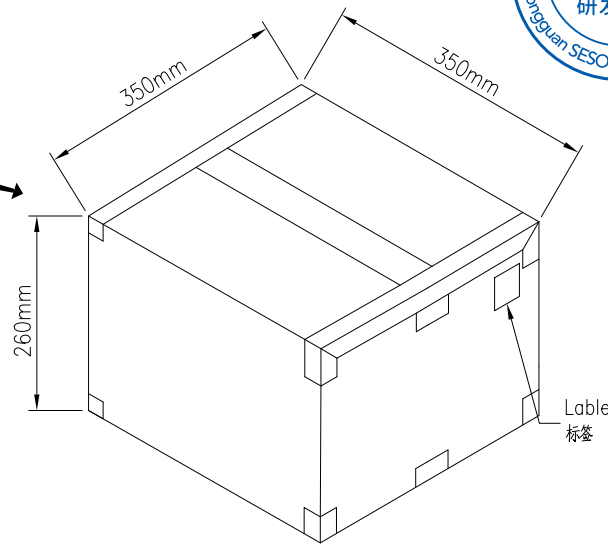

Step步骤3:



| | |
|----------------------------------|----------------------------------------|
| Applicable Product No. 适用产品料号 | 2201AM-2*XX/2*XXB/2*XXC/2*XXD-ESXX |
| | 2201AM-2*XXN/2*XXNB/2*XXNC/2*XXND-ESXX |
| | 2201AM-2*XXX-ESXX-V |

| Poles Pin位 | Pcs/Tray Pcs/盘 | Tray/Carton 盘/箱 | Pcs/Carton Pcs/箱 |
|------------|----------------|-----------------|------------------|
| 2*02 | 308 | 12 | 3696 |
| 2*03 | 308 | 12 | 3696 |
| 2*04 | 253 | 12 | 3036 |
| 2*05 | 231 | 12 | 2772 |
| 2*06 | 198 | 12 | 2376 |
| 2*07 | 176 | 12 | 2112 |
| 2*08 | 154 | 12 | 1848 |
| 2*10 | 132 | 12 | 1584 |
| 2*12 | 110 | 12 | 1320 |
| 2*14 | 99 | 12 | 1188 |
| 2*16 | 88 | 12 | 1056 |
| 2*18 | 77 | 12 | 924 |
| 2*20 | 66 | 12 | 792 |

Packing step包装步骤:

Step 1: Place the inspected product with TPA facing downwards, arrange neatly and in the same direction into the uptake plastic tray, the quantity cannot be reduced.

步骤1: 将检验好的良品TPA朝下, 整齐并方向一致地摆放入吸塑盘, 不可少数。

Specification of the uptake plastic tray: 2201SP-3400*3400*207

吸塑盘规格: 2201SP-3400*3400*207

Step 2: Overlap the uptake plastic tray, when it overlaps, adjacent upper and lower tray need to be rotated 180 degrees for stacking. One empty uptake plastic tray is stacked together in every 12 products, and put one on the top layer as well, fold them up into a bundle, then cross and parallel wrap with PE film.

步骤2: 将吸塑盘重叠, 在重叠吸塑盘时, 相邻上下两盘需要旋转180度堆叠, 每12盘产品加顶层放1PCS空吸塑盘叠起来为1扎, 然后用PE膜井字型缠绕。

Step 3: One bundle per carton, put it flat into the carton, then seal the carton with transparent tape, attach outer carton label.

步骤3: 每1扎为一箱, 平整地放入外箱内, 然后用透明胶带封箱, 贴上下箱标签。

Note: when the carton is not full, filling material is required, cannot shake too much.

注: 不满箱时, 需使用填充物, 不可晃动太大。

Carton size: CB-350*350*260KK

纸箱规格: CB-350*350*260KK

Carton material: K=K; Carton thickness: 6~7mm

纸箱材质: K=K; 纸箱厚度: 6~7mm

| | | | | | | |
|----------|----|------|-------------------------------------------------------------------|----------------|------------------|------------|
| 20250210 | A3 | / | Added 2*07Pin location specifications 增加2*07Pin规格 | Tim Teng 滕敏 | Larry Yang 杨蒙 | 一般公差 |
| 20240116 | A2 | / | Update Drawing 更新图面 | Tim Teng 滕敏 | Larry Yang 杨蒙 | .X ±0.35 |
| 20230202 | A1 | / | Added 2*02-2*05PIN packaging specifications 增加2*02-2*05PIN包装规格 | Tim Teng 滕敏 | Larry Yang 杨蒙 | .XX ±0.25 |
| 日期 | 版次 | 变更编号 | 变更内容说明 | 变更人 | 核准 | .XXX ±0.15 |
| | | | | | | .X ±2 |

| | |
|----|------------|
| 审核 | 杨蒙 |
| 审查 | 刘中华 |
| 制作 | 滕敏 |
| 日期 | 2022/03/15 |

SMS 东莞市思索技术股份有限公司
Dongguan SESO Technology Co., Ltd.

| | | | | |
|-----|------------------------------|-----|----|-------|
| 图号: | PK-2201AM-2*XXX-ESXX-X | | | |
| 名称: | Pitch 2.20mm Housing Packing | | | |
| 单位 | 比例 | 页次 | 版本 | 编号 |
| mm | 1:1 | 1/1 | A3 | A-000 |

RoHS

本产品符合我司QA-3-04-005
环境管理物质标准规范

包装图

Note注释:

- Quantity数量: 5K PCS/REEL一卷5K/PCS ; 8 REEL/BOX 一箱8卷; 40K PCS/BOX 一箱40K/PCS
每盘和外箱都必须有标签及环保标签分别标示
- Each reel and outer box must be labeled and Eco-Label Respectively labeled
- Terminal winding direction as shown端子缠绕方向如左图所示
- There shall be no dirt such as deformation phenomenon, Mantissa box fillers must be used
每箱不可有脏污,变形现象,尾数箱必须用填充物
- Carton material: K=K, Carton thickness: 6~7mm 纸箱材质:K=K, 纸箱厚度:6~7mm
- The paper tape shall be white paper tape with adhesive film and moisture proof
纸带需使用带胶膜防潮白色纸带
- One waterproof bag, two packets of desiccant 10g and four triangle guard plates should be placed in each carton
每箱里面要放一个防水袋和两包干燥剂10g及四个三角护板
- Up and down "工" type sealing form
上下"工"字型封箱形式
- Storage conditions: Temperature 10~30 ℃; Humidity 20%~65%RH
存储条件: 温度10~30℃; 湿度20%~65%RH

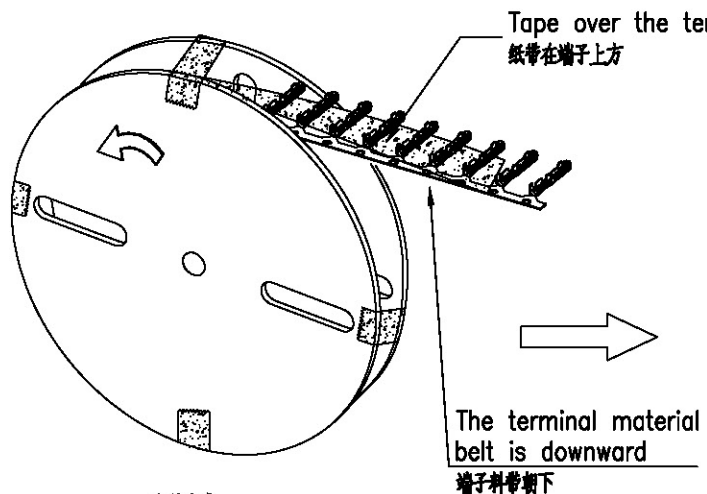
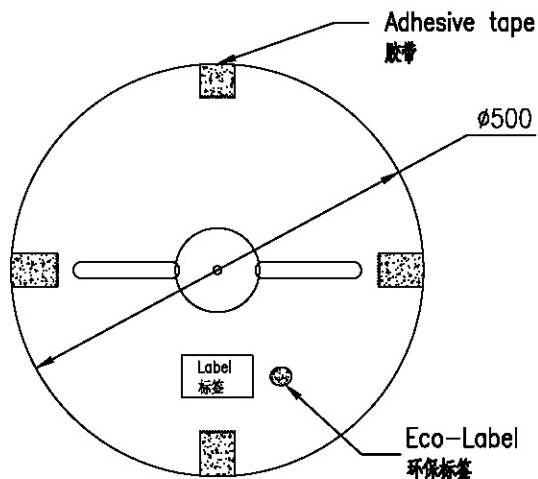

卷装方式
Package way

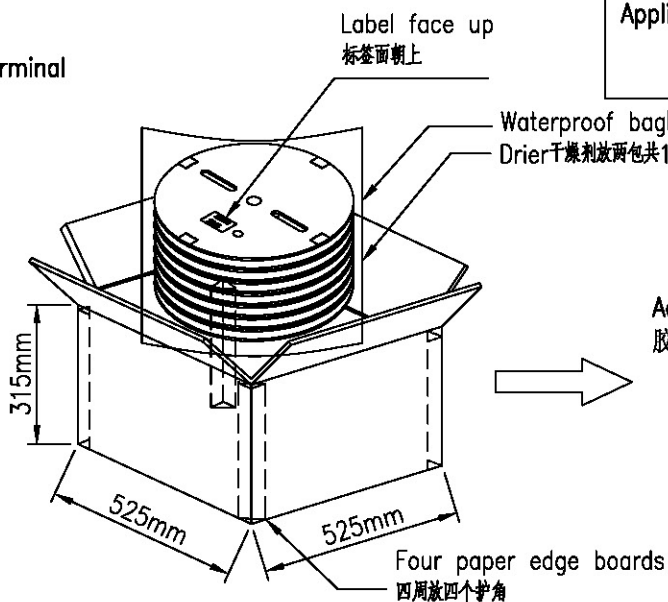

| | |
|----------------------------------|----------------|
| Applicable Product No. 适用产品料号 | 2201TF-HY2B-X |
| | 2201TLF-HY2B-X |
| | 2201THF-HY2B-X |

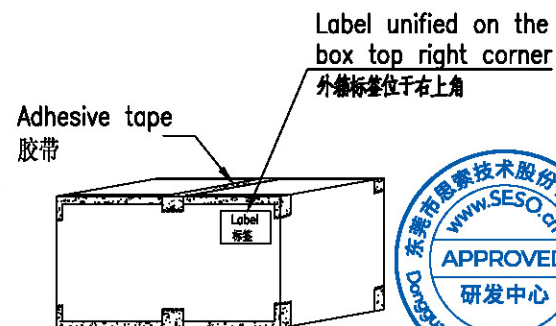

| 日期 | 版次 | 变更编号 | 变更内容说明 | 变更人 | 核准 |
|----------|----|------|-------------|-----|----|
| 20221016 | A1 | / | 修改纸盘外径与纸盘尺寸 | 刘中华 | 杨蒙 |
| 20220311 | A0 | / | 首次发行 | / | 杨蒙 |

一般公差

| | |
|------|-------|
| .X | ±0.35 |
| .XX | ±0.25 |
| .XXX | ±0.15 |
| X | ±2 |

核准 审查 制作 日期

杨蒙 / 刘中华 2022/03/11

| | | | | | |
|-----|-------------------------|-----|----|-------|--|
| 料号: | PK-2201TXF-HY2B-X | | | | |
| 名称: | 2.20mm Terminal Packing | | | | |
| 单位 | 比例 | 页次 | 版本 | 编号 | |
| mm | 1:1 | 1/1 | A1 | A-000 | |

RoHS

本产品符合我司QA-3-04-005
环境管理物质标准规范

包装图

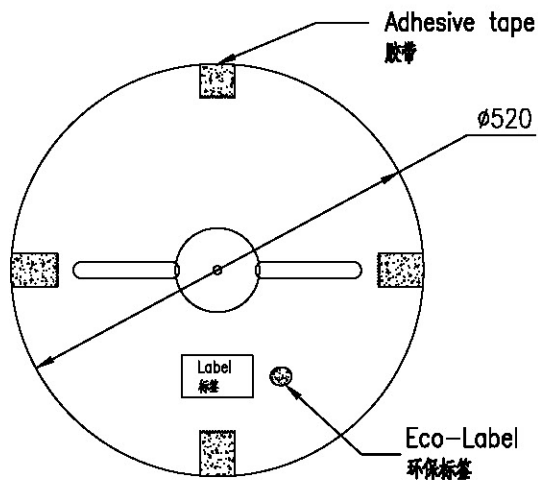

Note 注解:

- Quantity 数量: 5K PCS/REEL一卷5K/PCS ; 7 REEL/BOX 一箱7卷; 35K PCS/BOX 一箱35K/PCS
- Each reel and outer box must be labeled and Eco-Label Respectively labeled
每卷和外箱都必须有标签及环保标签分别标示
- Terminal winding direction as shown
端子缠绕方向如左图所示
- There shall be no dirt such as deformation phenomenon, Mantissa box fillers must be used
每箱不可有脏污,变形现象,尾数箱必须用填充物
- Carton material: K=K, Carton thickness: 6~7mm
纸箱材质:K=K, 纸箱厚度:6~7mm
- Up and down "工" type sealing form
上下"工"字型封箱形式

| | |
|----------------------------------|---------------|
| Applicable Product No. 适用产品料号 | 2201TM-BXX-X |
| | 2201TLM-BXX-X |
| | 2201THM-BXX-X |

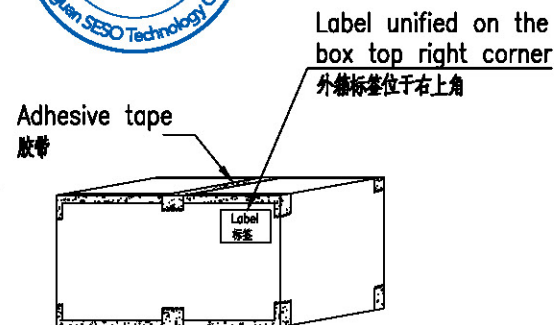
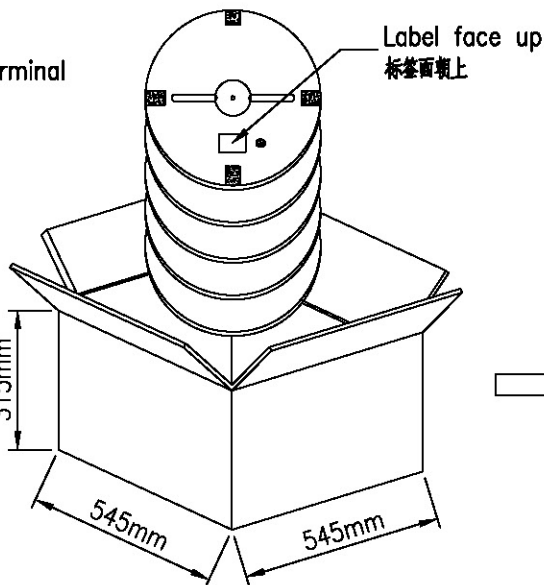
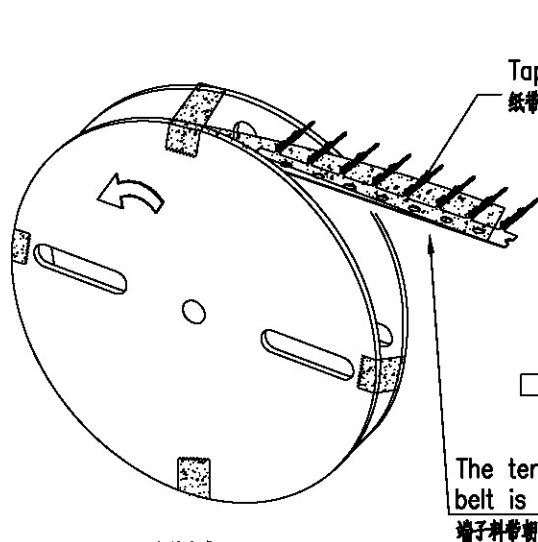

卷装方式
Package way

| | | | | | | | | | | | | | | | |
|----------|----|------|--------|-----|-----------|------------|-----------------------------------------------------------|----|-----|------------|-----------------------------|-----|-----|----|-------|
| | | | | | 一般公差 | | 东莞市思索技术股份有限公司 Dongguan SESO Technology Co.,Ltd. | | | | 料号: PK-2201TXM-BXX-X | | | | |
| | | | | | .X ±0.35 | | | | | | 名称: 2.20mm Terminal Packing | | | | |
| | | | | | .XX ±0.25 | | | | | | | | | | |
| 20220311 | A0 | / | 首次发行 | / | 审核 | .XXX ±0.15 | 核准 | 审查 | 制作 | 日期 | 单位 | 比例 | 页次 | 版本 | 编号 |
| 日期 | 版次 | 变更编号 | 变更内容说明 | 变更人 | 核准 | X: ±Z | 审核 | / | 刘中华 | 2022/03/11 | mm | 1:1 | 1/1 | A0 | A-000 |

RoHS

本产品符合我司QA-3-04-005
环境管理物质标准规范

包装图

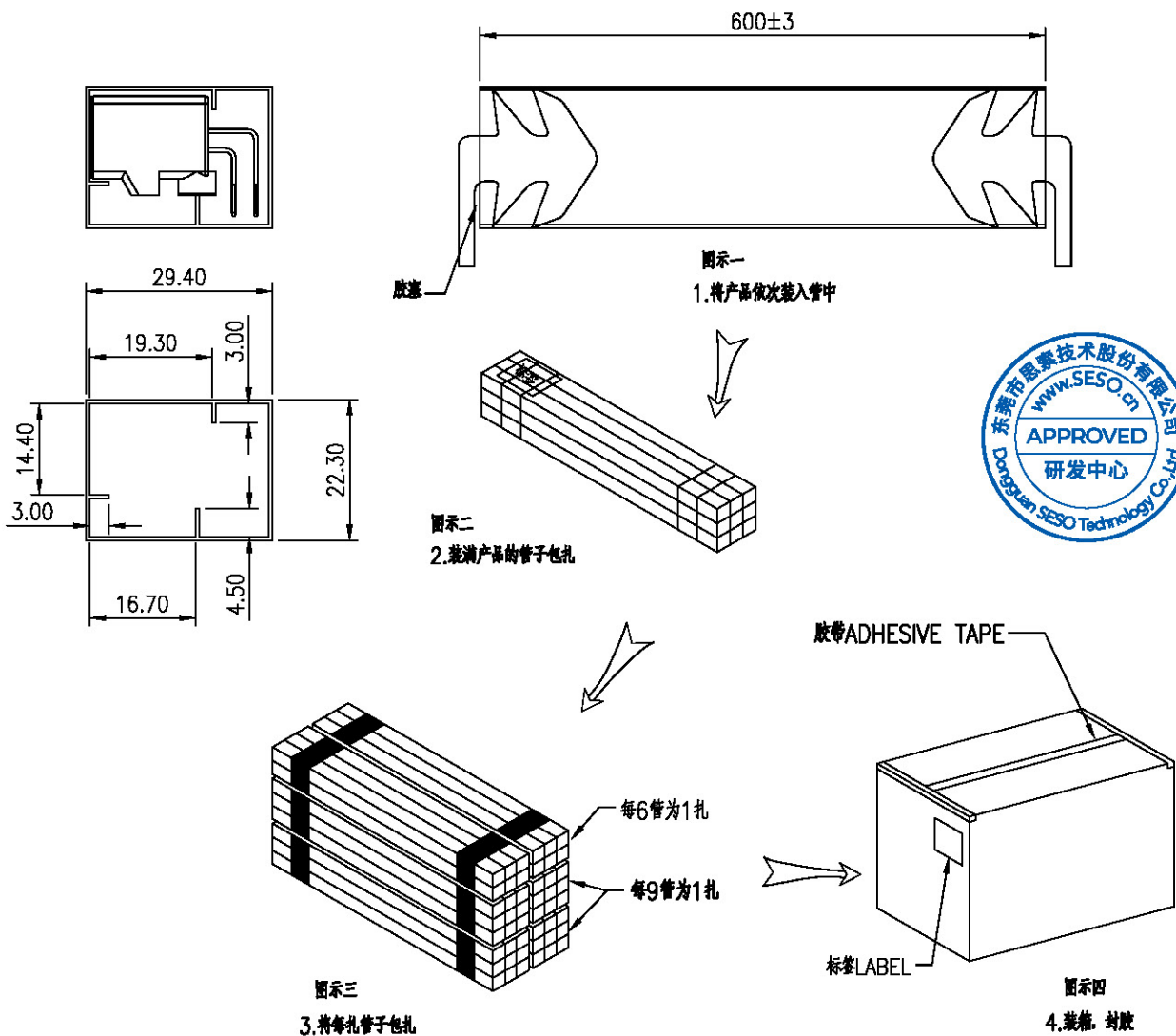

说明:

1. 将产品依图示方向放入真空管内, 方向须一致, 每个真空管放的产品数量依Pin数不同而不同, 具体详见包装明细表, 真空管两头用胶塞塞住, 如图一。
2. 将装好产品的真空管平放在桌面上以3PCS为一排然后再叠放3列或2列为1把如图二或图三, 整理好后用PE膜将1把真空管两头PE膜缠绕包好, 并在左边PE膜处贴1PCS产品标签, 如图示二。
3. 将上步完成的产品以每把进行包扎, 包装成一整扎, 如图示三。
4. 将包扎好的产品放入纸箱内, 并将纸箱用胶布封好, 在其侧面右上角贴上出货标签。
5. 纸箱规格: 600*200*180mm
- 真空管规格: 600*29.4*22.3mm
6. 纸箱厚度: 6~7mm



| PIN数 | 每支真空管数量 PCS/管 | 每箱真空管数量 PCS/箱 | 每箱包装数量 PCS/箱 |
|------|------------------|------------------|-----------------|
| 2*02 | 55 | 48 | 2640 |
| 2*03 | 43 | 48 | 2064 |
| 2*04 | 36 | 48 | 1728 |
| 2*05 | 34 | 48 | 1632 |
| 2*06 | 30 | 48 | 1440 |
| 2*08 | 24 | 48 | 1152 |
| 2*10 | 20 | 48 | 960 |
| 2*12 | 17 | 48 | 816 |
| 2*14 | 15 | 48 | 720 |
| 2*16 | 13 | 48 | 624 |
| 2*18 | 12 | 48 | 576 |
| 2*20 | 11 | 48 | 528 |

| | | | | | | 一般公差 | | | | 料号: PK-2201WR-2*XX-SSXXXXX-X 名称: Pitch 2.20mm Tube Packing | | | | |
|---|----------|----|------|--------------------|-----|------|-------|-------|----|---------------------------------------------------------------|-----|--|------------|--|
| | | | | | | .X | ±0.35 | | | | | | | |
| A | 20230202 | A1 | / | 增加2*02-2*05PIN包装规格 | 廖敏 | 杨豪 | .XX | ±0.25 | | | | | | |
| | 20211225 | A0 | / | 首次发行 | / | 邹洪 | .XXX | ±0.15 | | | | | | |
| | 日期 | 版次 | 变更编号 | 变更内容说明 | 变更人 | 核准 | X: | ±Z | | | | | | |
| | | | | | | | 角 | | 核准 | | 刘中华 | | 2021/12/25 | |
| | | | | | | | 角 | | 核准 | | 杨豪 | | A-000 | |

RoHS

本产品符合我司QA-3-04-005
环境管理物质标准规范

包装图

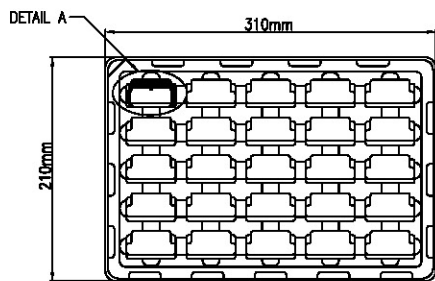

步骤:1

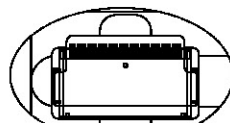
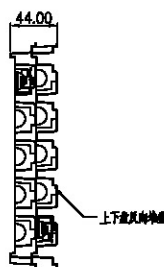
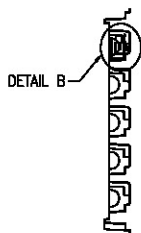

局部放大图A
比例3:1

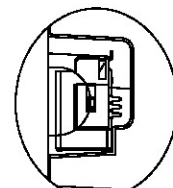

局部放大图B
比例4:1

| Pin位 | 盘/Pcs | 箱/盘 | 箱/Pcs |
|------|-------|-----|-------|
| 2*02 | 55 | 14 | 770 |
| 2*03 | 50 | 14 | 700 |
| 2*04 | 50 | 14 | 700 |
| 2*05 | 45 | 14 | 630 |
| 2*06 | 45 | 14 | 630 |
| 2*08 | 40 | 14 | 560 |
| 2*10 | 35 | 14 | 490 |
| 2*12 | 30 | 14 | 420 |
| 2*14 | 25 | 14 | 350 |
| 2*16 | 25 | 14 | 350 |
| 2*18 | 20 | 14 | 280 |
| 2*20 | 20 | 14 | 280 |

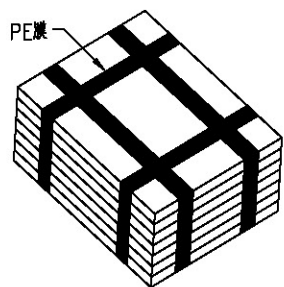

步骤:2

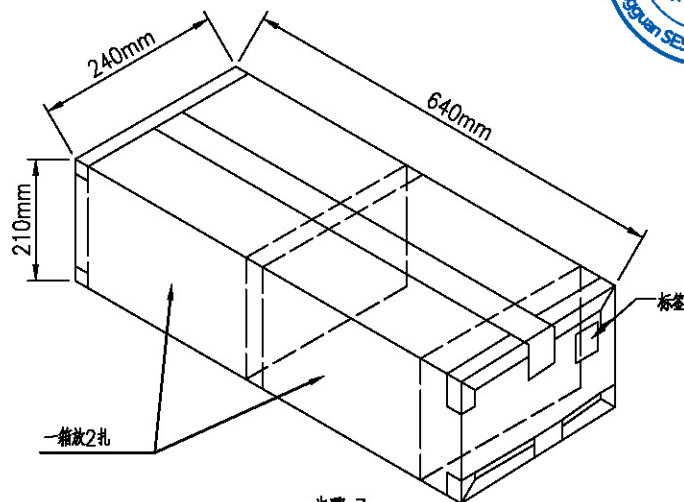

步骤:3

包装说明:

- 步骤1: 将检验好的2201WRS-2*XXCX-PPSW1XT良品整齐摆放入吸塑盘。
吸塑盘规格: 310*210*25.4mm
吸塑盘材质: PET;
- 步骤2: 在重叠吸塑盘时, 上下层吸塑盘方向需错开摆放, 7盘叠起来为1扎, 最顶层再放1PCS空吸塑盘当上盖用, 然后用PE膜扎住, 并套上防水袋。
- 步骤3: 一纸箱里放2扎, 共14盘, 然后用透明胶带封箱, 贴上外箱标签。
纸箱规格: 640*240*210mm
纸箱材质: K=K; 纸箱厚度: 6~7mm

| | | | | | | 一般公差 | | | | 料号: PK-2201WRS-2*XXCX-PPSW1XT-X | | | |
|----------|----|------|--------|-----|----|--------------------------------------------------------|-------|-----|-------|------------------------------------|--|--|--|
| | | | | | | .X | ±0.35 | .XX | ±0.25 | | | | |
| | | | | | | .XXX | ±0.15 | X: | ±2 | 单位: mm | | | |
| 日期 | 版次 | 变更编号 | 变更内容说明 | 变更人 | 核准 | 核准 | | | | | | | |
| 20221209 | A1 | / | 修改包装数量 | 陈智浩 | 杨蒙 | SMS 东莞市思索技术股份有限公司 Dongguan SESO Technology Co.,Ltd. | | | | 杨蒙 / 刘中华 2022/06/29 | | | |
| 20220629 | A0 | / | 首次发行 | / | / | 杨蒙 / 刘中华 | | | | 2022/06/29 | | | |
| | | | | | | 比例: 1:1 | | | | 页次: 1/1 | | | |
| | | | | | | 版本: A1 | | | | 编号: A-000 | | | |

RoHS

本产品符合我司QA-3-04-005
环境管理物质标准规范

包装图

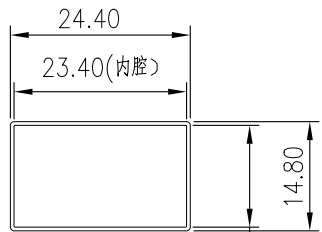

Rubber stopper
胶塞

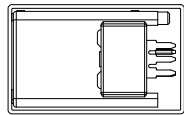
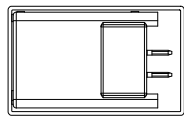

Product matching diagram
产品匹配图

600±2₀

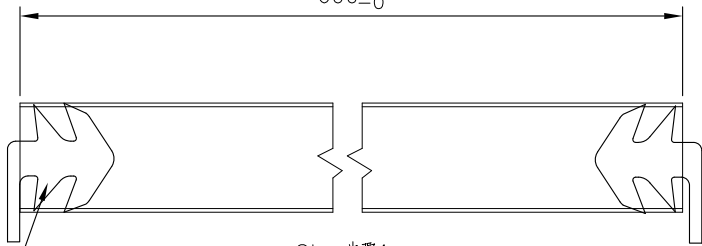

Step 步骤1:

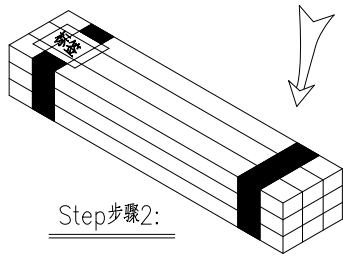

Step 步骤2:



| | |
|----------------------------------|----------------------------------------------------|
| Applicable Product No. 适用产品料号 | 2201WV-2*XX/2*XXB/2*XXC/2*XXD-PPXXXG |
| | 2201WV-2*XXN/2*XXNB/2*XXNC/2*XXND-PPXXXG |
| | 2201WV-2*XXL/2*XXLB/2*XXLC/2*XXLD-PPXXXG |
| | 2201WV-2*XXF/2*XXFL/2*XXFLB/2*XXFLC/2*XXFLD-PPXXXG |
| | 2201WV-2*XXX-PPXXXG-V |

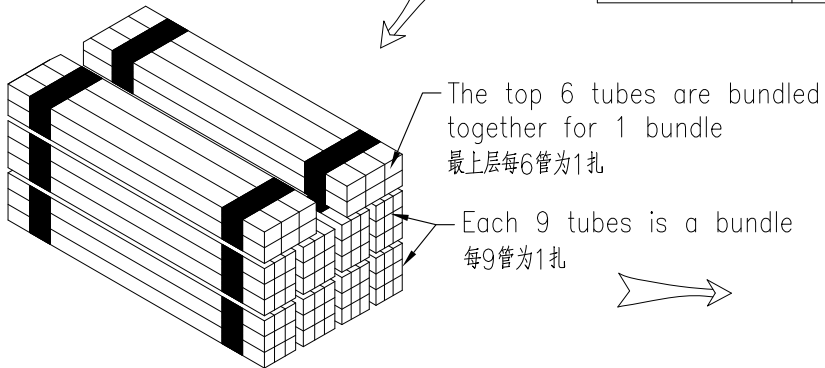

Step 步骤3:

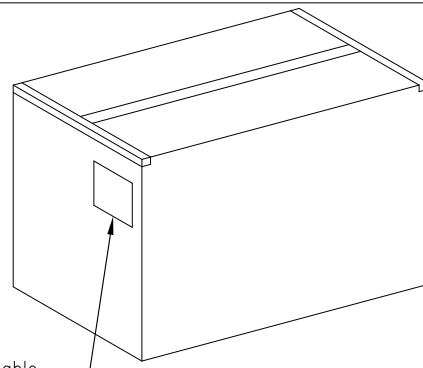

Lable
标签

Step 步骤4:

Packing step 包装步骤:

Step 步骤1: Place the product into the vacuum tube as shown in the figure, in the same direction, without omission. Use rubber plugs to plug both ends of the vacuum tube.

将产品如图示依次装入真空管内, 方向须一致, 不可少数, 真空管两头用胶塞塞住。

Vacuum tube specifications 真空管规格: 2201TD-600*249*148

Step 步骤2: Put the vacuum tubes loaded with products in the same direction on the table and stack them. After finishing, wrap the two ends of the 1-tie vacuum tubes with PE film.

将装好产品的真空管方向一致地放在桌面上堆叠, 整理好后将1扎的真空管两头用PE膜缠绕包好。

Step 步骤3: Every 10 bundles of products are packed in one box and placed flat inside the outer box.

每10扎产品为一箱, 平整地放入外箱内。

Step 步骤4: Seal the cardboard box with tape, and then attach the outer box label on the right side outside the box.

将纸箱用胶带封好, 然后在箱外右侧贴上外箱标签。

Note: When the box is not full, filling material should be used and should not be shaken too much.

注: 不满箱时, 需使用填充物, 不可晃动太大。

纸箱规格 Carton Size: CB-600*200*180mmKK

纸箱材质 Carton material: K=K

纸箱厚度 Carton thickness: 6~7mm

| Poles Pin位 | Pcs/Tube Pcs/管 | Tube/Carton 管/箱 | Pcs/Carton Pcs/箱 |
|---------------|-------------------|--------------------|---------------------|
| 2*02 | 38 | 84 | 3192 |
| 2*03 | 32 | 84 | 2688 |
| 2*04 | 28 | 84 | 2352 |
| 2*05 | 26 | 84 | 2184 |
| 2*06 | 24 | 84 | 2016 |
| 2*07 | 22 | 84 | 1848 |
| 2*08 | 20 | 84 | 1680 |
| 2*10 | 17 | 84 | 1428 |
| 2*12 | 15 | 84 | 1260 |
| 2*14 | 13 | 84 | 1092 |
| 2*16 | 12 | 84 | 1008 |
| 2*18 | 11 | 84 | 924 |
| 2*20 | 10 | 84 | 840 |

| | | | | | | |
|----------|----|------|--------------------------------------------------------------------------|--------------------|------------------|------------|
| 20250211 | A3 | / | Added 2*07Pin location specifications 增加2*07Pin规格 | Tim Teng 滕敏 | Larry Yang 杨蒙 | 一般公差 |
| 20230706 | A2 | / | Modify the width of the pipe according to the actual size 依实物修改管子宽度尺寸 | Zhihao Zhen 陈智浩 | Larry Yang 杨蒙 | .X ±0.35 |
| 20230206 | A1 | / | Added 2*02-2*05PIN packaging specifications 增加2*02-2*05PIN包装规格 | Tim Teng 滕敏 | Larry Yang 杨蒙 | .XX ±0.25 |
| 日期 | 版次 | 变更编号 | 变更内容说明 | 变更人 | 核准 | .XXX ±0.15 |
| | | | | | | .X ±2 |

SMS 东莞市思索技术股份有限公司
Dongguan SESO Technology Co., Ltd.

| | | | | |
|----------------------------------|-----|-----|----|-------|
| 图号: PK-2201WV-2*XXX-PPXXXG-X | | | | |
| 名称: Pitch 2.20mm Tube Packing | | | | |
| 单位 | 比例 | 页次 | 版本 | 编号 |
| mm | 1:1 | 1/1 | A3 | A-000 |

| | | | |
|----|-----|----|------------|
| 核准 | 审查 | 制作 | 日期 |
| 杨蒙 | 刘中华 | 杨梅 | 2021/12/15 |

RoHS

本产品符合我司QA-3-04-005
环境管理物质标准规范

包装图

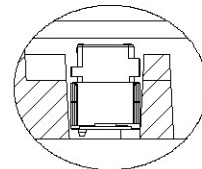
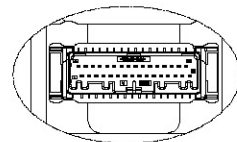
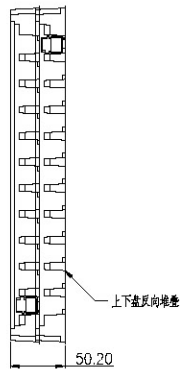
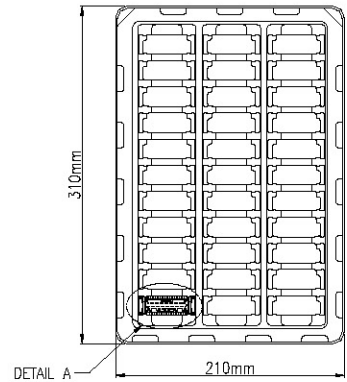

| Pin位 | 盘/Pcs | 箱/盘 | 箱/Pcs |
|------|-------|-----|-------|
| 2*02 | 66 | 14 | 924 |
| 2*03 | 66 | 14 | 924 |
| 2*04 | 55 | 14 | 770 |
| 2*05 | 55 | 14 | 770 |
| 2*06 | 55 | 14 | 770 |
| 2*08 | 44 | 14 | 616 |
| 2*10 | 44 | 14 | 616 |
| 2*12 | 44 | 14 | 616 |
| 2*14 | 33 | 14 | 462 |
| 2*16 | 33 | 14 | 462 |
| 2*18 | 33 | 14 | 462 |
| 2*20 | 33 | 14 | 462 |

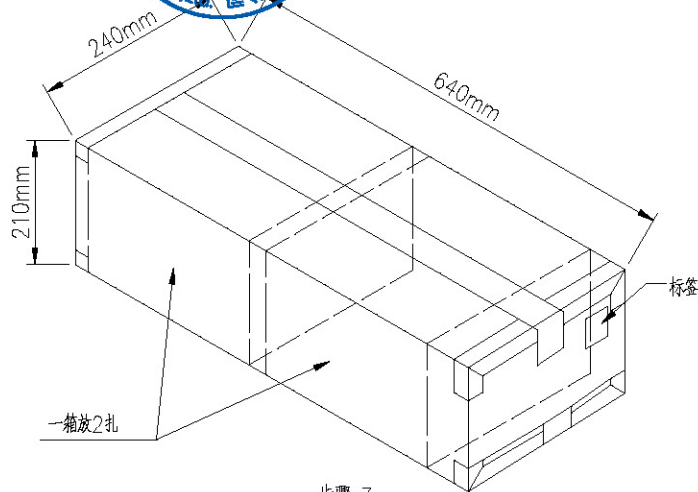
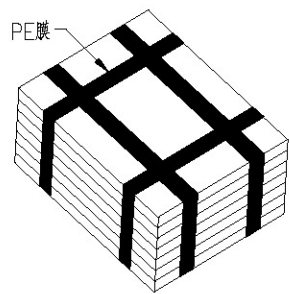

包装说明:

步骤1: 将检验好的2201WS-2*XXXX-PPSW1XT/PPSW1XY良品整齐摆放入吸塑盘。

吸塑盘规格: 310*210*25.4mm

吸塑盘材质: PET;

步骤2: 在重叠吸塑盘时, 上下层吸塑盘方向需错开摆放, 7盘叠起来为1扎, 最顶层再放1PCS空吸塑盘当上盖用, 然后用PE膜扎住。

步骤3: 一纸箱里放2扎, 共14盘, 然后用透明胶带封箱, 贴上下箱标签。

纸箱规格: 640*240*210mm

纸箱材质: K=K; 纸箱厚度: 6~7mm

| 日期 | 版次 | 变更编号 | 变更内容说明 | 变更人 | 核准 |
|----------|----|----------------|--------|-----|-----|
| 20230609 | A1 | ER120230609001 | 修改包装数量 | 陈智浩 | 刘中华 |
| 20230107 | A0 | / | 首版发行 | 刘中华 | 杨蒙 |

一般公差
 .X ±0.35
 .XX ±0.25
 .XXX ±0.15
 X: ±2

SMS 东莞市思索技术股份有限公司
Dongguan SESO Technology Co., Ltd.

核准: 杨蒙
 审查: /
 制作: 刘中华
 日期: 2023/01/07

| | | | | |
|-----------------------------------------|-----|-----|----|-------|
| 料号: 2201WS-2*XXX-PPSW1XX-X | | | | |
| 名称: 2.20mm Vertical Header Tray Packing | | | | |
| 单位 | 比例 | 页次 | 版本 | 编号 |
| mm | 1:1 | 1/1 | A1 | A-000 |